

**Summary**

**Features**

- ABL-ARRAY16P supports the SensL ArrayC 4x4 array of 3mm SiPMs
- Wideband amplifier per SiPM, 16 total
- DC-coupled signal path
- Low power consumption
- Precision temperature sensor
- SensL’s fast output signals are not used

**Mechanical**

- Mounting/alignment hole for #2 hardware
- 0.050” signal connector uses low-profile micro IDC cable assemblies for versatile placement



SiPM array not included

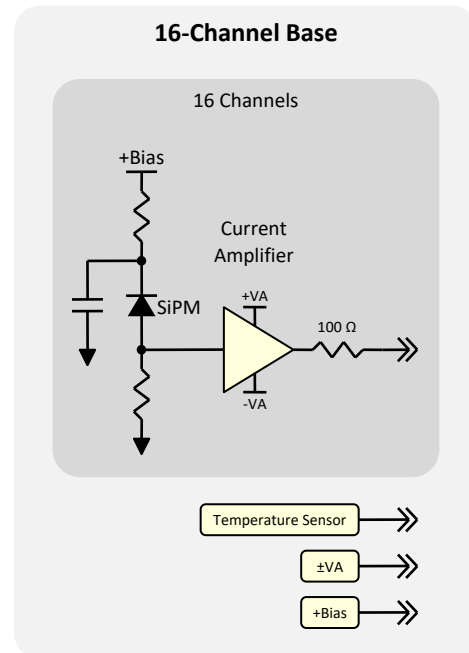

## Specifications

### SiPM Signal Amplifiers

Channels	16
Type	Transimpedance
Gain	750Ω
Rise time	< 20ns
Output voltage	0 → -1V (100Ω load)
Output impedance	100Ω
Output current	50mA max.

### Temperature Sensor

Output voltage	500mV + 10mV per °C
Output current	10mA
Output impedance	100Ω
Accuracy	±0.5°C

### Bias Voltage

+28V typical  
(refer to manufacturer's data)

Over-voltage clamp 47V Zener diode

### Amplifier Power (±VA)

±2.8V typ.; ±5V max.

Current ±30mA typ.  
(I<sub>q</sub>, no signal, no load)

### Signal Connector

Right angle 26-pin 2-row header  
0.050" pin pitch

Mating assembly Samtec FFSD-13-D-XX.XX-01-N  
(XX.XX = length in inches)

### Array-16P

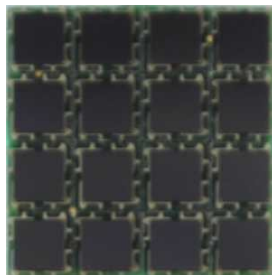

### Array Channel Map

(Facing Array)

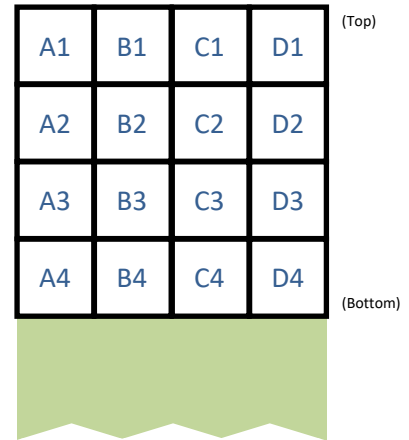

### Signal Connector

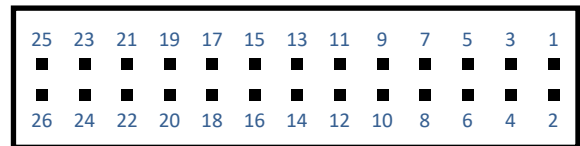

PCB Side View

Pin	Function	Pin	Function
1	D4	2	Temperature
3	D1	4	GND
5	D2	6	D3
7	C4	8	GND
9	C1	10	C3
11	C2	12	-VA
13	B4	14	GND
15	B1	16	+VA
17	B2	18	B3
19	A4	20	GND
21	A1	22	A3
23	A2	24	GND
25	+Bias	26	GND

**Mechanical**

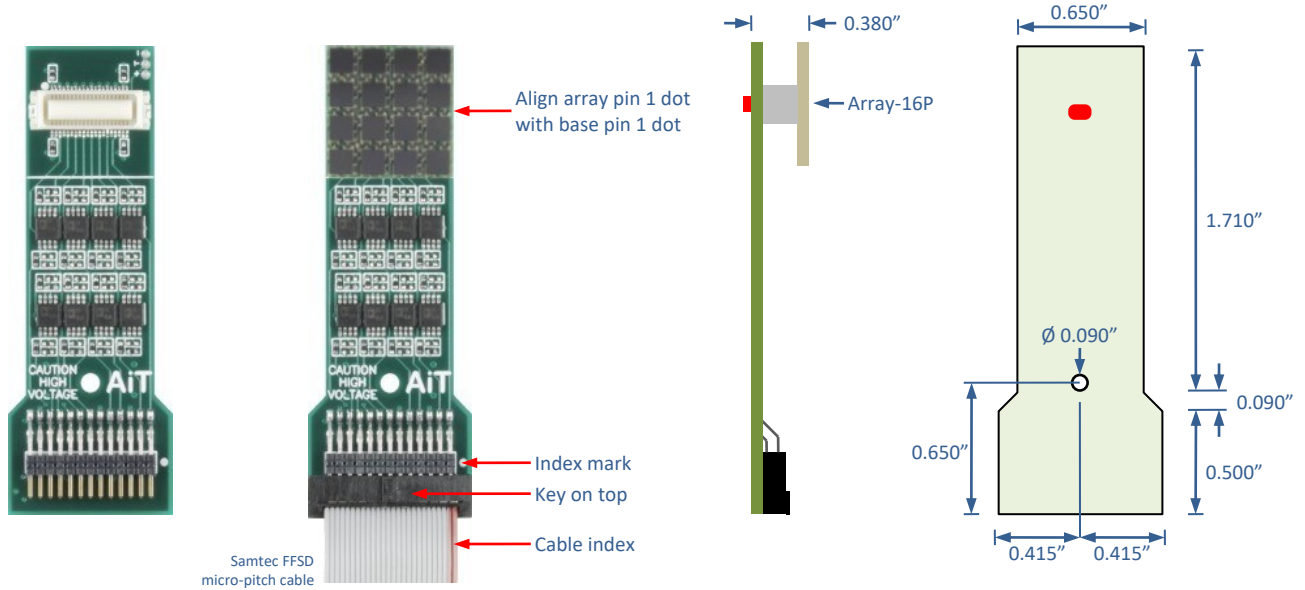

● Approximate location of temperature sensor on bottom side of PCB  
Measurement tolerance:  $\pm 0.020''$

## Safety Information



### **WARNING – High Voltage**

- High voltage may be present during operation
- High voltage stored on capacitors may be present after power is removed
- Improper handling may result in personnel injury or equipment damage

This high-voltage device must be used only by personnel trained and qualified in safe handling, installation, and operation of high-voltage equipment.



### **CAUTION – Electrostatic Discharge (ESD) Sensitivity**

The circuit board can be damaged by electrostatic discharge. Observe precautions for handling electrostatic sensitive devices. Handle only at static-safe workstations.

## High-Gain Photodetectors

High-gain photodetectors such as silicon photomultipliers may conduct damaging currents if exposed to high optical signal levels while the bias voltage is applied, or if the bias voltage exceeds the recommended operating range. These devices must be operated only in low-light conditions, and only within the manufacturer's recommended bias voltage range.

## Handling and Disassembly

This product may be provided with or without a protective enclosure. Disassembled enclosure components and circuit boards may contain sharp edges. Take appropriate safety precautions while assembling or disassembling the enclosure and handling disassembled components.

## Indoor Use Only

Do not operate this product in a wet/damp environment. Do not operate in an explosive atmosphere.

Use of this product, and AiT Instruments' liability related to use of this product, is further governed by AiT Instruments' standard terms and conditions of sale, which were provided upon purchase of this product.